

T-16A STAINLESS STEEL LINE BODY - LT16SS

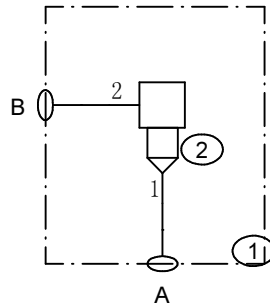

ITEM ID	PART NUMBER	QTY	DESCRIPTION
1	LT16SS	1	T-16A STAINLESS STEEL LINE BODY
2	T-16A	1	SUN CAVITY

ITEM ID	PORT SIZE
A, B	G 1-11

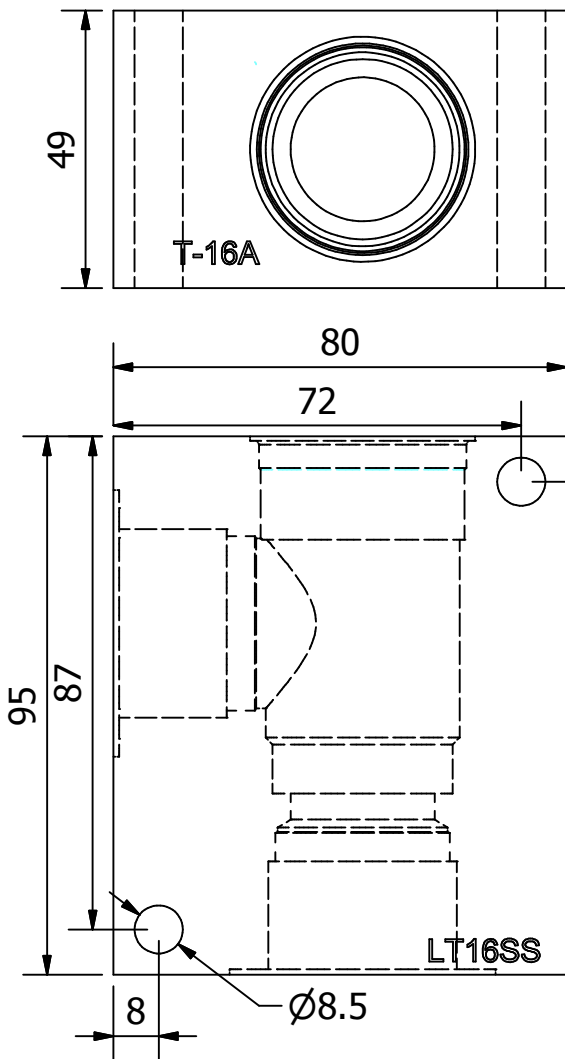

Part Number: LT16SS
Description: T-16A Stainless Steel Line Body
Material: 316 Stainless Steel
Max Pressure: 350 Bar
Mounting: 2x $\varnothing 8.5$ mm Through Holes
Valves: CNGC, CNHC, CXGD, CXHA, CXHF, DFEA, DFEB, FCEB, FDEA, FLHA, FQGA, FXEA, NCFB, NCGC, NFEC, NFED, RDHA, RPIC, RPIE, RPIT

Part No.	Material	Weight Kg	Price
LT16SS	316 Stainless Steel	2.1	\$1250



Temisi Engineering Pty Ltd
 65 Shaun Parade
 Elimbah, 4516
 QLD
 Web: www.Temisi.com
 Email: Sales@temisi.com

This document contains Proprietary
 Information and is NOT to be
 Reproduced without the Written
 Permission from TEMISI ENGINEERING
 PTY LTD.
 Dimensions, Specifications and Prices
 are Subject to change without notice.

T-16A LINE BODY

